

 **Harry Taylor**

CE

heatmiser
Effective Temperature Control

**HEATMISER
ECONOMY 2000/L**

 **Harry Taylor of Ashton Limited**

Internet: www.harrytaylor.co.uk / Email: info@harrytaylor.co.uk

Registered Office: Kitson's Works, Aylesbury Road, Bromley, Kent, BR2 0QZ

Northern Office: Units 1 - 3 Guide Bridge T/E, South Street, Ashton - u - Lyne, Lancs OL7 0HU

SOUTHERN SALES TEL: 020 8464 0915 / NORTHERN SALES TEL: 0161 308 4550

USER INSTRUCTIONS



INDEX

SUBJECT	PAGE No.
Contents Pages	2
Standard Terms	3
Normal RUN Mode	
• Override	4
• Summer Mode	4
• Heater Lockout & Reset	4
• Summer Fan	5
Program Mode	
• Temperature Setting	5
• Data Settings	5
• Time Settings	6
• Code Setting	7
Technical	
• Override (maximum)	8
• Optimisation Configuration	8
• Code Setting	8
• Calibration	9
• Reset	9
• Service Mode	9
• Service Alarm Activated	9
• Resetting The Service Alarm	10
• Constant Fan	10
• Specification/Fuse Rating	10
• Wiring Diagrams	11 & 12

STANDARD TERMS

Self Learning Optimisation is a system whereby the Heatmiser Control will automatically calculate the start-up time to ensure the building is up to temperature for the programmed switching time. It does this by monitoring the internal temperature readings, so that for example, in milder weather conditions heat up times are reduced – thus saving energy.

Preheat is the number of hours the control can come on before the programmed switching time (when in optimising mode). This is set under the Engineers code and can be set to no more than 8 hours.

Rate of change is the time it takes to raise the building 1°C. The factory default for this setting is 20 minutes but the control will automatically adjust this according to the fabric of the building.

Override: Using the Override button on the Heatmiser Keypad allows the user to override the zone for a selected number of hours, to allow for unscheduled use of the system. A maximum can be set to stop users entering long override periods.

Switching period status:

- **Day** is when the control is being controlled to an actual switching time. (For example between 07.00 - 08.00 the control would be in a DAY condition. Outside of those hours the control would be in a NIGHT condition).
- **Night** is when no switching times have been programmed. At these times the control is set back to the night temperature.

Heater Lockout & Reset is standard on the Heatmiser 2000L and allows a signal to be fed into the Heatmiser from the heater when the heater goes to lockout (overheat etc.). Once the fault on the heater has been rectified a reset signal can be sent to the heater resetting lockout status.

Normal RUN mode is when the control is operating normally and is not being programmed (i.e. showing the Time/Day or the Info screen). It is important to remember that when any alterations have been made to the Heatmiser's program, the RUN button is pressed to return the control to the RUN mode.

NORMAL MODE

There is one main Normal (RUN) mode screen, and one Info Screen on the Heatmiser Economy 2000/2000L. These are explained below:

The Normal (RUN) mode screen shows information such as Current Time, Current temperature and the relay status.

MON 13:06 20C Status: HEAT OFF

The Information screen shows the target temperature along with the switching period.

TARGET TEMP: 21C TIME CLOCK: DAY

To view the Information screen, press INFO and select 1 for Information.

OVERRIDE



The Heatmiser Economy 2000/2000L can be overridden into a day or night condition to allow for any unscheduled operation of the system. The maximum time that the unit can be overridden will have been set by the installer.

To program an override period

- From the Normal RUN mode
Press the Override button and enter your security code if required.

Mon 13:06 20C
Time Clock: DAY

- Then choose 1) to enter the override mode.

1> OVERRIDE MODE
2> SUMMER MODE

- Then select either 1 or 2 to override the zone ON(1) or OFF(2).

OVERRIDE TO
1>ON or 2>OFF

- You are now prompted to enter the length of the override period.

OVERRIDE SETTING
MAXIMUM (04) : 03

- Should the zone be above temperature, the control will show the following screen. Remember that the Override function only overrides time and not temperature. This error message will also appear if the override time programmed exceeds the maximum override setting

** WARNING **
INVALID DATA

- The status screen then indicates the zone has been put into an override condition.

Mon 13:06 20C
Status: OVERRIDE



To cancel an override period repeat the steps above, choosing 2 for OFF and then reduce the length of the override period to 00.

SUMMER MODE

To enable the Summer mode facility press the Override/Summer button and select 2 for Summer.

1> **OVERRIDE MODE**
2> **SUMMER MODE**

The control is then put in to Summer mode, which means that the temperature is controlled to the Night Setback setting.

To cancel repeat the above operation.

HEATER LOCKOUT/RESET

(Available only on the Economy 2000L)

A supply can be wired into the Heatmiser from the heater lockout connection allowing for remote indication of a fault. Once the fault has been rectified on the Heater, pressing RESET on the keypad sends a reset signal to the heater to clear the lockout status. This feature is highly beneficial on heaters installed out of reach.

HEATER RESET

(No Lockout Indication)

On heaters where there is no heater lockout, the Heatmiser can be used to send a reset signal.

To send a Reset signal in this case:

Press the Reset button.

Press 2 for Reset.

1> INFORMATION
2> LOCKOUT RESET

The Reset relay will be energised for a second.

MANUAL SUMMER FAN



Providing the installed heaters are equipped with a summer fan facility, the Heatmiser can enable the fan to give ventilation in summer months.

- Pressing the FAN key displays the following screen.
- At this point you must press ENTER or if you wish to abort this operation press the DELETE key.

FAN ON?
ENTER TO CONFIRM

! To disable the fan, repeat the above operation.

PROGRAM MODE

From the Normal (RUN) mode screen, pressing the PROG button will display the following screen:

** WARNING **
ENTRY CODE: ????

Before you can access the Heatmiser you must enter the passcode. This passcode is set to 0000 as a factory default but may be changed at any time by the user to ensure security. This process is explained under section 4 (Code).

1) TEMP

This section is used to change the temperature settings.

This is the DATA menu

1>TEMP 2>DATA
3>TIME 4>CODE

Pressing 1 for TEMP displays the following screen:

- You are now prompted to enter the required temperature for the DAY periods. (EG - 22). This must be entered as two digits.
- When complete, press Enter.
- You are now able to select whether you require Frost Protection. Selecting OFF returns you to the DATA menu.
- Selecting ON enables you to select a NIGHT setback temperature.
- Press Enter when you have set the required night temperature, and then press RUN to return to the Normal RUN Mode.

SET DAY PERIOD
TEMP: 22 C

FROST PROTECTION
1>ON OR 2>OFF

SET NIGHT PERIOD
TEMP: 05 C

2) DATA

The DATA section is where you are able to set the daily switching periods. There are 3 periods per day available.

- Press PROG and enter the security code.
- Now select 2 to enter the DATA menu.

1) TEMP 2) DATA
3) TIME 4) CODE

You can see on screen now that we are prompted to enter the switching period 1 for Monday. So, using 24 clock notation, enter the required Start Time. (EG 08:00).

MON PERIOD : 1
S:HH:MM E:HH:MM

Now Press Enter to accept the Start Time and to move the cursor to the End Time setting.



We are able to program the required End Time, for example 17:00. Don't forget to use 24 hour clock notation. When complete, press Enter to accept the programmed switching time and to move onto Period 2 Monday.

MON PERIOD : 1
S:HH:MM E:HH:MM

Programming further periods

You are now able to program Period 2 Monday in just the same way. Press Enter when complete.

MON PERIOD : 2
1) S:21:00 E:23:00

Should you not require all three switching periods – simply leave the times at HH:MM and this period will be ignored.

MON PERIOD : 3
1) S:HH:MM E:HH:MM

At this point Press the Enter key to move onto Tuesday's switching periods.

You are able to enter the switching periods for Tuesday in just the same way.

TUE PERIOD : 1
1) S:HH:MM E:HH:MM

Should the switching periods be the same on Tuesday, you can press the COPY button and this copies all of the switching times from the previous day. So, for example, if you were to press the COPY button on Tuesday period 1 all of the switching times from Monday would be copied, and then the Heatmiser would move onto Wednesday.

A screen is displayed similar to this . . . :

COPYING ALL DATA
MON TO TUE

 To correct any mistakes made, use the DEL key. If Enter is pressed at any display then the current settings will be retained.

3) TIME

This is the section used to set the current Time & Day.

- Press PROG and enter security code.
- Then select option 3 for Time.
- The time currently set is displayed on screen along with a prompt asking for the new time. Simply enter the new time remembering to use 24 hour clock notation. (EG: 14.23)
- As the Heatmiser Economy 2000 does not have a calendar, the current day must now be set. So for example, if today is Wednesday press 3.
- The control will then return to the DATA menu.
- Press RUN to return to the Normal RUN mode, you will now notice the correct time and day has been set.

TIME NOW: 13:23
NEW TIME: HH:MM

SET DAY OF THE WEEK
1 = MON = > **7 = SUN**



4) CODE

- Press Prog and enter security code.
- Pressing 4 for Code prompts you to select the code you wish to alter.

1> Manager Code - This code gives access to all data settings.

2> Override Code - This code gives access to the Override and Summer functions.

1> MANAGER CODE
2> OPERATORS CODE

- To change the code, simply enter the new code when prompted.

CODE NOW: 0000
NEW CODE ????

- Press Run to return to the Normal RUN mode.



Setting the Manager and Operations code to the same disables the Operators code.
(i.e. No code is required to access the operators section)

TECHNICAL INFORMATION – ENGINEERS SET UP



To enter the engineers section, press the program button and enter the Engineers Code. (This will be found on a label stuck to the fascia or on the reverse side of the keypad. This label should be removed after the control has been commissioned.

A display like the one shown will now be displayed.

1> OVERRUN	2> OPT 1
3> CODE	4> SETUP

1) OVER

This section allows us to enter a limit for the override.

OVERRIDE SETTING MAXIMUM TIME: 08

Enter two digits (eg 08, for 8 hours) and then press enter to accept the setting.

2) OPTI

With the Heatmiser Economy 2000/2000L you are able to set whether optimisation is required. (Refer to Terms for further information).

Should you require optimisation select 1 for ON and then continue to set the following parameters.

OPTIMISATION? 1> ON or 2> OFF

Selecting OFF returns you to the Setup Menu and turns off optimisation. This means that the control will switch the heating ON at the programmed switching time and will not allow for any warm up period.

This is the amount of time the heating system takes to raise the building temperature by 1°C. An average starting point would be 20 minutes but because the unit is self learning, it will alter itself by 1 minute per day to adjust itself to the correct setting.

RATE OF CHANGE MINUTES /C :20

This is the maximum number of hours before the entered switching time that the unit could come on to raise the building up to the temperature. The maximum setting is 8 hours but an average setting is 3 hours.

SET PRE HEAT MAXIMUM TIME :03

3) CODE

The code section will work as normal and is used to set the User's code.

4) SET UP

This section allows us to set the service mode, calibrate the sensors, reset the system to factory defaults and enable or disable the constant fan facility.

1> CAL	2> RESET
3> SERVICE	4> C.FAN

CALIBRATION



Selecting 1 for calibration enables the engineer to calibrate the sensor if required.

- To calibrate the sensor, simply enter the actual temperature you have recorded in the zone. Be sure to take the temperature from next to the Heatmiser control.
- Press RUN to return to the Normal Run Mode
- The temperature will then be displayed on the screen.

CURRENT: 22
ACTUAL: XX

RESET

This function resets the Heatmiser Economy's settings back to the factory defaults.

To put the control through a reset:

- Press 4 for Setup
- Press 2 for Reset
- Pressing ENTER at this point will erase all data. To abort press the DELETE key.

1 > CAL 2 > RESET
3 > SERVICE 4 > C.FAN

RESET ALL DATA
ENTER TO CONFIRM

SERVICE MODE

- Enter the Engineers code and press 3 for service.
- You are now prompted to:
1> Configure the service mode or
2> Reset the current hours run total held in the unit.
- Pressing 1 to configure the unit will display the following screen and will ask you to turn the service mode On or Off.
- You are now required to enter the number of hours the system may run before the Service Alarm should be activated. Press Enter to accept the programmed setting.
- You should now enter the full phone number that you want displayed when a Service Alarm is activated.

1 > CAL 2 > RESET
3 > SERVICE 4 > C.FAN

1 > CONFIGURATION
2 > RESET DATA

SERVICE MODE
1 > ON or 2 > OFF

SERVICE MODE
HOURS RUN: 0000

SERVICE MODE
CALL: 00000000

SERVICE ALARM ACTIVATED.

When a Service Alarm has been activated a warning screen will be displayed for 5 seconds every minute. You are able to cancel this warning by pressing RESET whilst the warning display is on screen.

Remember that you will not receive further Service Alarms until the control has been reset by an engineer.

RESETTING THE SERVICE ALARM



After a service alarm has been activated you are able to reset the hours setting without the need to reprogram the telephone number by selecting Reset from the Configuration/Reset screen.

CONSTANT FAN

On the Economy 2000L there is an option to have a Constant Fan output. If enabled the Fan Relay will be permanently ON during the programmed switching times and will operate to the optimiser setting.

- To enable the constant fan enter the Engineers code and press 4 for setup.
- Then press 4 for C.FAN and select 1 for ON. This will enable the constant fan facility.
- Select 2 to disable this feature.

1> CAL	2> RESET
3> SERVICE	4> C.FAN

CONSTANT FAN	
1> ON	OR 2> OFF

SPECIFICATION

Zones:	1 Control Zone
Time-bases:	1 Time-base can be programmed with a maximum of 3 switching periods per day, 7 days a week.
Outputs:	2000 = 2 Single pole normally open contact (10 amp 230v AC Resistive) 2000L = 3 Single pole normally open contact (10 amp 230v AC Resistive)
Sensor Type:	Built in sensor only
Battery Backup:	3 Years
Supply:	230v \pm 10% 50Hz
Relay Output:	Normally open contacts maximum rating 230v AC 10 Amp Resistive
Dimensions:	158mm x 62mm x 199mm
Weight:	0.85kg
Enclosure:	ABS Designed to comply with IEE regulations

FUSE RATING

F1 = 800ma AS
F2 = 315ma QB

ECONOMY 2000 WIRING DIAGRAMS

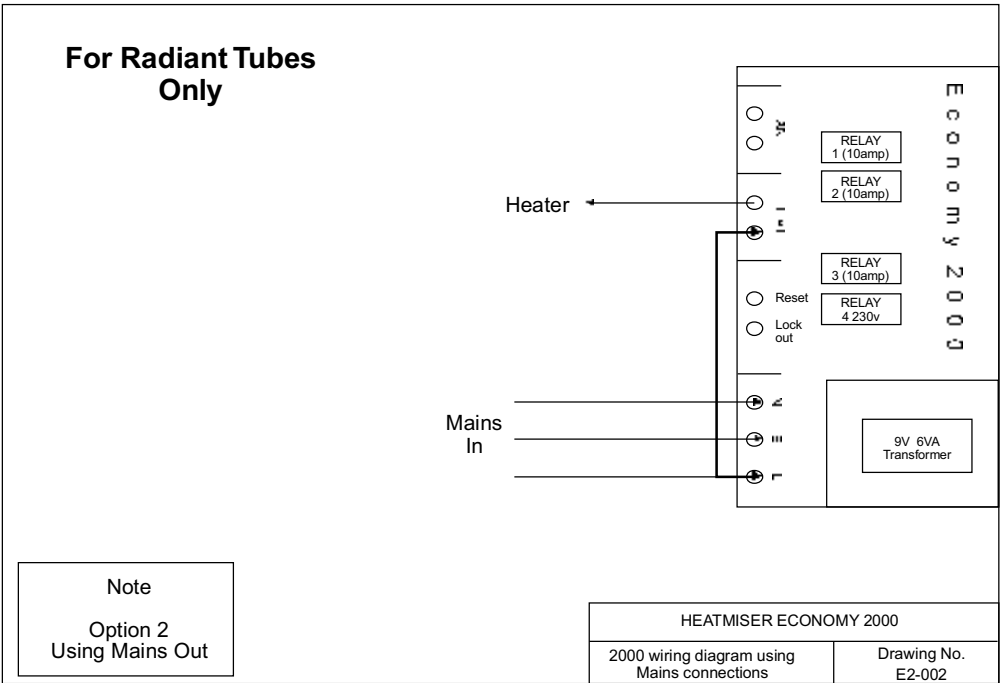
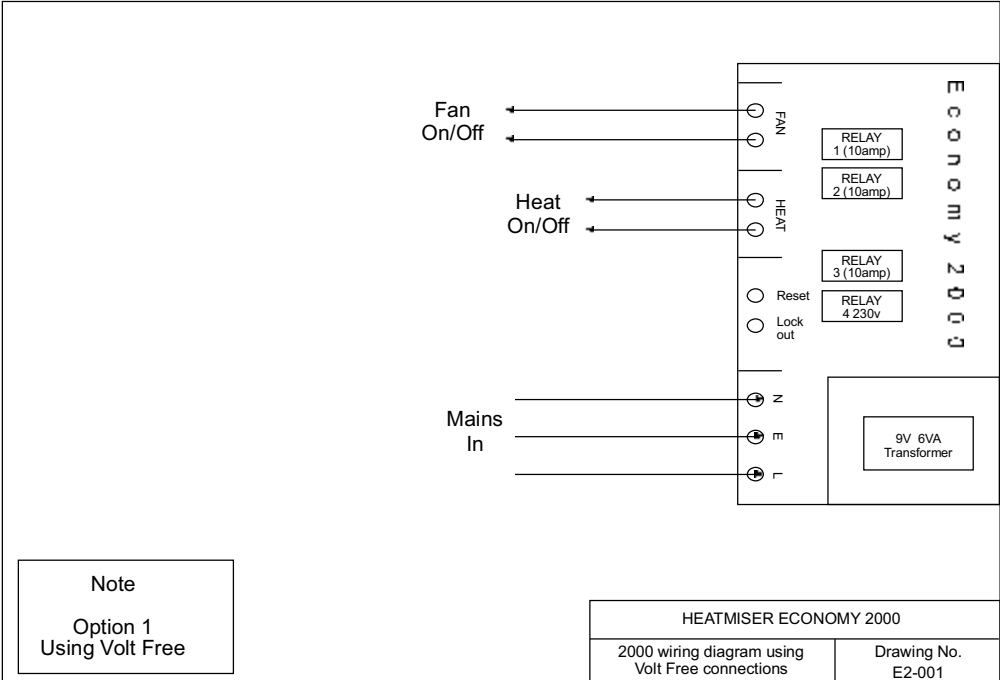

ECONOMY 2000L WIRING DIAGRAMS

