

## Warm air heaters / HT2000 heater range UPSA Room Sealed Low-Nox unit heaters

ErP Ready 2021

Low Nox

CE & Building Regulations Compliant

Sealed Combustion Circuit

Modulating Burner

Automatic Operation

Digital Optimised Heating Controls

Frost Protection

Summer Fan operation



ACCREDITED  
SUPPLIER

“Taylor” made solutions from the company with the know - how

### Overview

The UPSA series is a range of gas fired unit heaters designed to deliver outstanding energy efficiency, performance and economy for reduced operating and life cycle costs.

Reliable operation and simple servicing further reduce operating costs whilst the extended operational life of the heat exchanger ensures that the units provide the lowest long term cost benefits.

### Product Features

- Standard axial fan heater throws up to 36m.
- Compact space saving dimensions, designed to be room sealed or power flued with vertical or horizontal option.
- Low NOx and high energy output with highest efficiency without condensing, simple and efficient high - low burner control.
- Dual limit stats provide additional safety and reliability
- Advanced burner technology utilises a fully pre-mixed blown burner, with multi-try ignition for optimum reliability and ease of maintenance
- A microprocessor burner control provides full safety monitoring and multitry ignition control for enhanced reliability.

### Specification

- Wide range of sizes, twelve capacities from 10 to 120kW
- UPSA heaters incorporate 4-pass heat exchanger technology for optimum efficiency and enhanced life expectancy.
- The fan operation is controlled by an integral controller which delays the fan start up until the heat exchanger has reached operating temperature and continues to run the fan after the burner has switched off until all useful heat has been dissipated
- Single burner with multi-try ignition provides enhanced reliability
- A fully pre-mixed blown gas modulating burner is fitted as standard
- Heaters will be capable of use with G20 Natural Gas or G31 LPG with injector change.
- Supplied with a modulating gas valve assembly as standard
- Low NOx
- High efficiency
- Powder coated heater casing
- suitable for a single phase electrical supply

## Technical Data

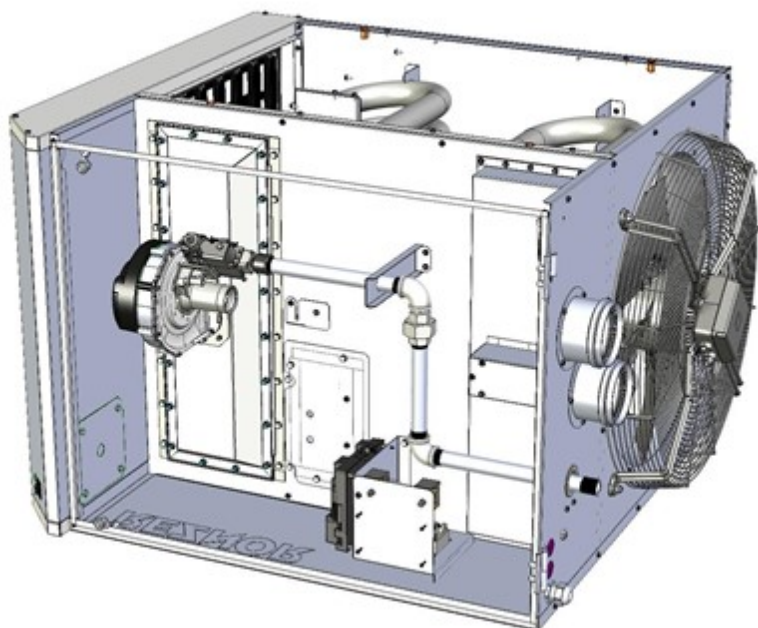

Enhanced Reliability & Safety

Heat Exchanger  
Manufactured from aluminised steel

Air Flow  
High capacity axial flow fan

Burner  
Fully premixed with multi-try ignition

Dual Limitstats  
Provide additional safety

Model	UPSA	30	70	90	115	150	200	225	250	330	410
Combustion Air and Flue Type		B23 / B53 / C13 / C33 / C53									
Heat Output High Fire	kW	9.34	18.39	26.54	31.68	42.24	53.46	63.59	71.25	97.87	120.16
Gas Consumption High Fire (HS) G20	m <sup>3</sup> /h	1.07	2.14	3.08	3.69	4.91	6.17	7.37	8.19	11.33	13.71
Gas Connection	BSP	½"			¾"						1"
Airflow	m <sup>3</sup> /h	1223	2533	3035	4120	4562	5877	7125	8681	10350	17552
Horizontal Throw	m	10	16	26	27	26	32	32	36	36	36
Noise Level	dBA	46	48	49	51	51	51	56	59	60	62
Minimum mounting height	m	2.5									
Recommended mounting height	m	3.0			4.0					4.0 - 5.0	
Total Electrical Rating	W	145	150	256	550	550	690	820	1000	1040	1900
Electrical Connection		230V / 1N / 50Hz									
Protection Grade	IP	IP20									
Net weight	Kg	43	63	58	89	99	121	122	135	168	258

### Harry Taylor South:

Kitsons Works, Aylesbury Road,  
Bromley, Kent,  
BR2 0QZ, UK

Tel: 020 8464 0915

Email: [southernoffice@harrytaylor.co.uk](mailto:southernoffice@harrytaylor.co.uk)

### Harry Taylor North:

Guide Bridge Mill, South Street,  
Ashton-under-Lyne, Lancs  
OL7 0UH, UK

Tel: 0161 3084550

Email: [northernoffice@harrytaylor.co.uk](mailto:northernoffice@harrytaylor.co.uk)