

Harry Taylor

CELEBRATING **90** YEARS

Warm air heaters / HT2000 RST heater range

Room sealed gas and propane fired suspended warm air heaters

High efficiency

CE & Building Regulations Compliant

Sealed combustion circuit

Stainless steel heat exchanger option

Automatic operation

Space saving off floor installation

Optimised control

Centrifugal options available



“Taylor” made solutions from the company with the know - how



Axial fan heaters:
For conventional cross flow warm air discharge.



Centrifugal fan heaters:
For ducted heating systems.



Bi-Directional heaters:
For warm air discharge in two directions saving on both capital and installation costs.



Downward discharge:
For uniformity of heat discharge and reduced levels of heat stratification.

Visit us online: www.harrytaylor.co.uk

Warm air heaters / HT2000 RST heater range

Room sealed gas & propane fired suspended warm air heaters

Compact, quiet and yet highly efficient HT2000 RST heaters provide cost effective heating for most commercial and industrial buildings. Offering space saving 'off-floor' mounting VRA gas unit heaters discharge warmth directly into the space to be heated in a conventional cross-flow manner. VRBD heaters discharge in two directions and by so doing significantly reduce both capital and installation costs. VRE heaters have downward air discharge characteristics and combine uniformity of heating with high levels of de-stratification. VRC versions are suitable for ducted systems.

Technical Data	Model Ref											
	40	70	100	115	135	150	170	200	250	330	410	490
Model series	3	3	3	3	2	3	2	3	3	3	3	3
Nominal heat output kW	11.1	21.8	26.0	36.2	39.0	44.6	49.0	60.9	73.1	94.5	119.3	137.4
Airflow m ³ /h	1122	2045	2326	3170	3456	4270	4356	5214	7282	8024	10764	11400
Temperature rise K	29	31	33	33	34	31	33	34	29	34	32	35
Throw m	9.5	13.0	17.0	24.0	20.0	25.0	23.0	30.0	32.0	31.0	38.0	39.0
Gas Consumption												
Natural gas G20 m ³ /h	1.27	2.52	3.02	4.19	4.50	5.19	5.63	6.98	8.38	11.19	13.80	15.77
Propane G31 kg/h	TBC	1.86	2.22	3.09	3.20	3.82	4.00	5.15	6.17	8.24	10.17	11.62
Gas connection Rc	½"	½"	½"	½"	½"	½"	½"	½"	¾"	¾"	¾"	¾"
Electrics												
Supply V/ph/hz	230/1/50	230/1/50	230/1/50	230/1/50	230/1/50	230/1/50	230/1/50	230/1/50	230/1/50	230/1/50	230/1/50	230/1/50
FLC												
VRA amps	2.3	1.6	2.3	3.1	1.2	3.1	1.6	5.4	5.4	4.3	3.1	3.1
Mounting height(s)												
VRA m	2.5	3.0	4.0	4.0	2.0-3.2	4.0	2.4-4.0	5.0	5.0	5.0	6.0	6.0
Flue diameter nom mmø	80	100	100	130	100	130	100	130	130	130	130	130
Combustion air diameter nom mmø	80	100	100	130	100	130	100	130	130	130	130	130
Maximum horizontal run m	9	9	9	9	6	9	6	9	9	9	9	9
Maximum vertical run m	9	9	9	9	10	9	10	9	9	9	9	9
Noise level (approx @ 3m) dB(A)	37	43	48	49	58	49	61	55	56	54	55	56
Net weight kg	90	90	95	126	104	131	120	148	160	229	242	279

Dimensions	Model Ref											
	40	70	100	115	135	150	170	200	250	330	410	490
Unit height A	567	567	567	845	650	845	910	845	845	845	960	1150
Unit width B	965	965	965	965	1050	965	1050	1298	1298	1298	1750	1750
Unit depth C	652	652	652	652	680	652	680	652	652	807	810	810
Overall depth D	782	785	821	824	893	824	893	824	824	1022	1022	1022
Suspension points E	611	611	611	611	755	611	755	942	942	942	1365	1365
Suspension points F	406	406	406	406	640	406	640	406	406	550	770	770
Top clearance	150	150	150	150	150	150	150	150	150	150	150	150
Rear clearance	450	450	450	450	450	450	450	450	450	450	450	450
Bottom clearance	150	150	150	150	150	150	150	150	150	150	150	150
Left-hand side clearance	150	150	150	150	150	150	150	150	150	150	150	150
Right-hand side clearance	800	800	800	800	800	800	800	800	800	800	800	800

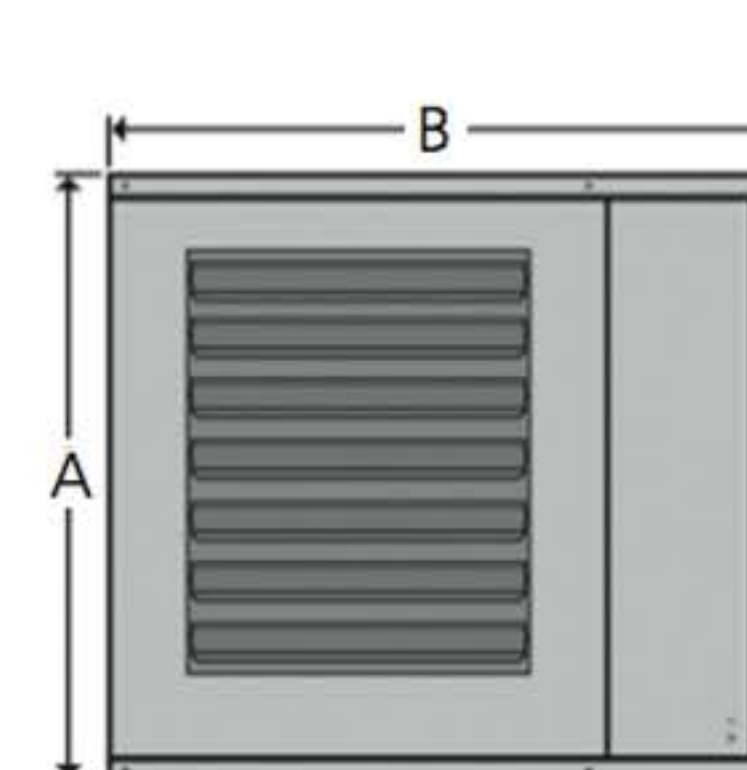

Front view

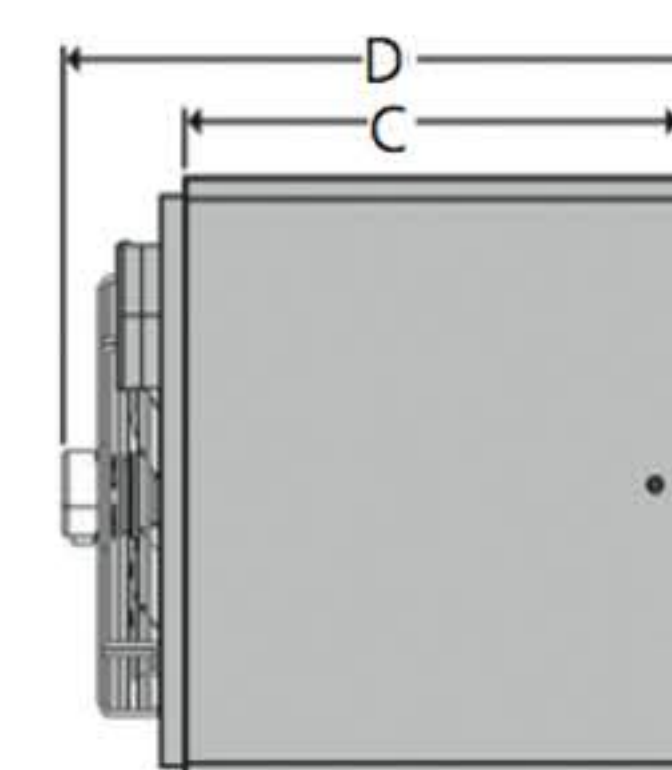

Side view

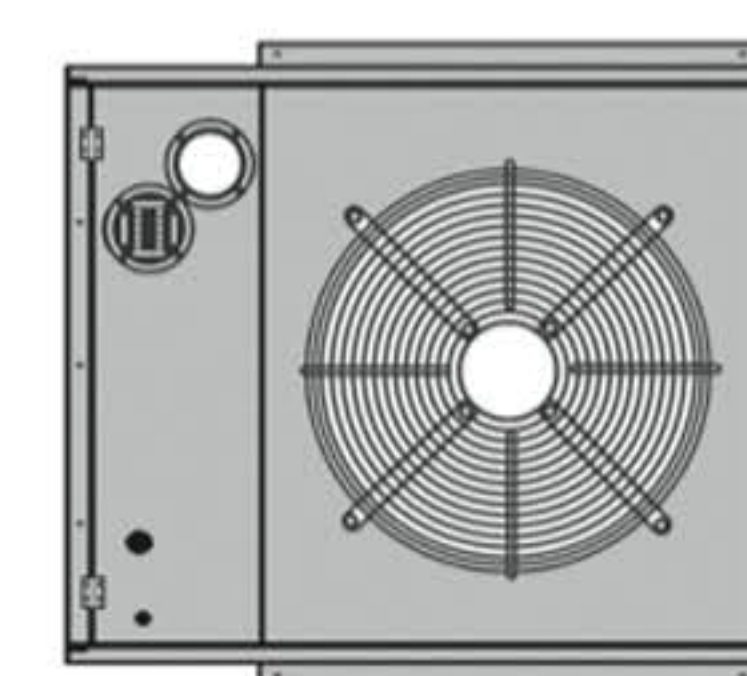

Back view

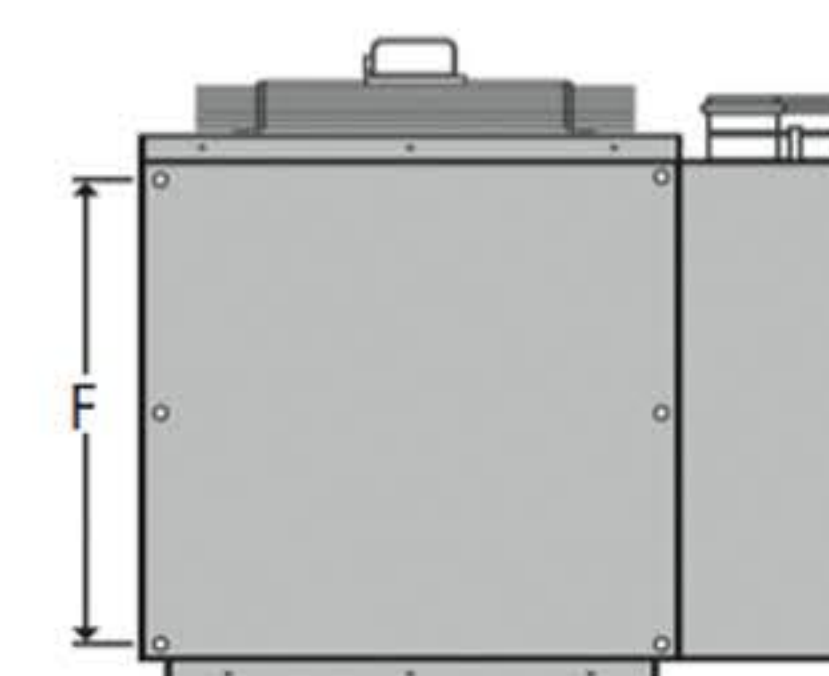

Plan view

Specification:

Application: A range of suspended gas fired unit heaters with clean aesthetic lines and configured for either room sealed or conventional flue applications. Suitable for showrooms, factories, workshops, warehouses, greenhouses and many other commercial premises. Off-floor mounting provides an ideal solution where floor space is at a premium.

Building Regulations & CE Approval: All RST gas unit heaters are designed with fuel efficiency in mind and meet the efficiency requirements of Part L2B of current Building Regulations as well as applicable CE legislation.

Construction: The casing is robotically formed from electro zinc coated steel sheet and finished with a durable stove hardened epoxy polyester powder paint whilst the heat exchanger is formed without the need for welding from either aluminised or stainless steel to form a four pass multi-tube assembly.

Burner: High efficiency low noise multi flame in-shot burner complete with automatic ignition and full flame safety monitoring. Available for natural gas or lpg propane.

Testing: Every heater is individually inspected, test fired and safety function tested prior to despatch.

Controls: Heaters are ready for automatic operation after the simple connection of the time and temperature control. We offer a fully optimised control which includes a secure entry code facility, temperature dependant start time, digital time switch with override facility, electronic day & frost protection thermostats and can be set to run on "fan only" to enable summer air movement.

Power Flue: Enables the heater to be used in room sealed or fan assisted flue format with both vertical and horizontally flue exit options.

Air Distribution: VRA heaters are fitted with powerful axial fans and discharge warm air through an outlet grille which is complete with adjustable horizontal louvres. VRBD heaters do likewise but discharge warm air in two opposing directions enhancing distribution whilst reducing capital and installation costs. VRE heaters have a downward discharge pattern whilst VRC heaters are designed for ducted applications and are fitted with centrifugal fans.

Guarantee: RST heaters are provided with one of the most comprehensive guarantee packages available -
Year One: Parts and labour
Year Two: Parts

Harry Taylor Southern office:
 Kitsons Works, Aylesbury Road,
 Bromley, Kent,
 BR2 0QZ, UK

Southern office tel: 020 8464 0915
southernoffice@harrytaylor.co.uk

Harry Taylor Northern office:
 Guide Bridge Mill, South Street,
 Ashton - under - Lyne, Lancs,
 OL7 0HU, UK

Northern office Tel: 0161 308 4550
northernoffice@harrytaylor.co.uk

 **Harry Taylor**
www.harrytaylor.co.uk